

# FRECAN

HIT 60/80/90/100/120

1

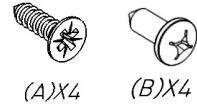
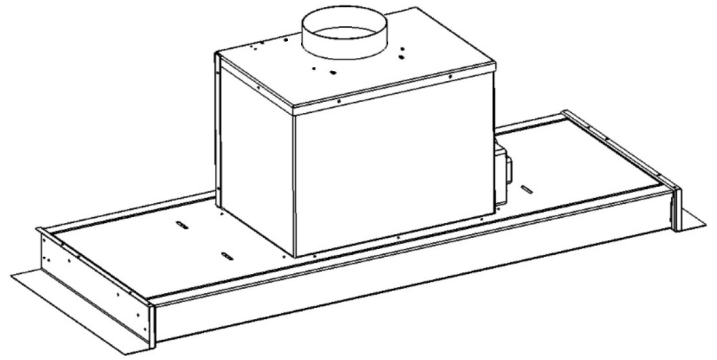

(A)X4

(B)X4

2

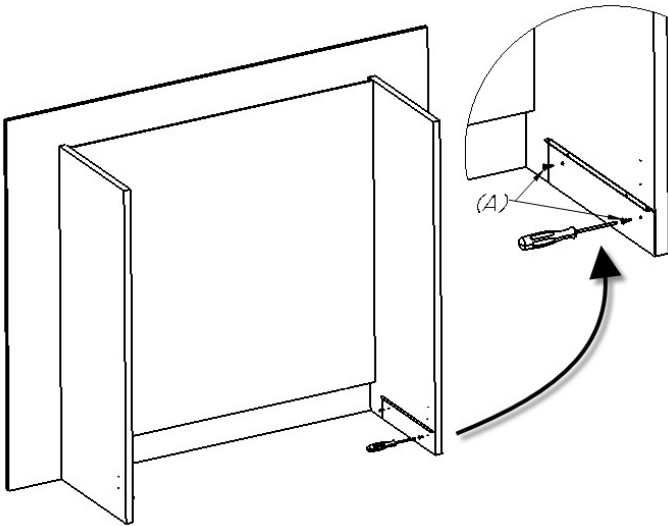

3

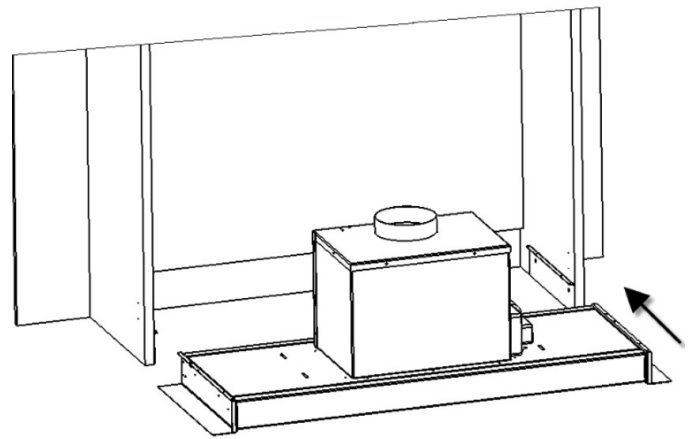

4

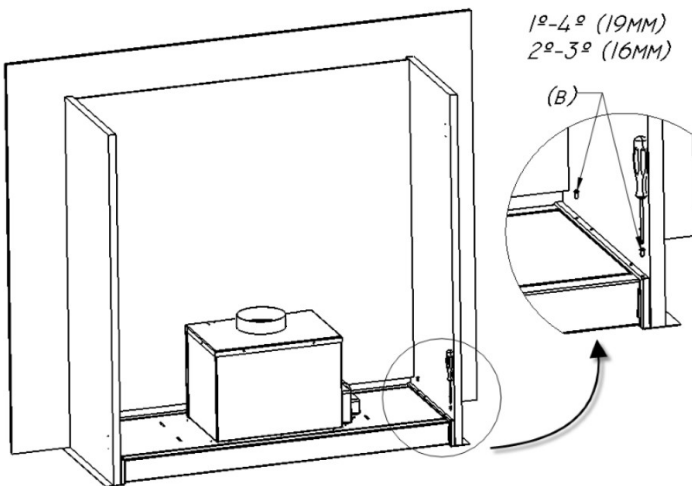

5

