

FRECAN

FLOW POUR

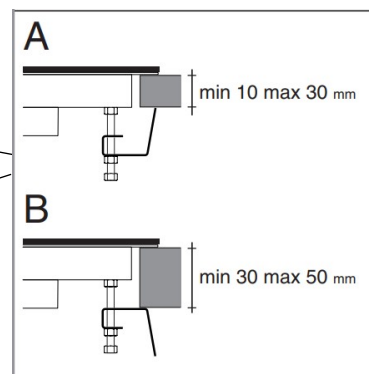
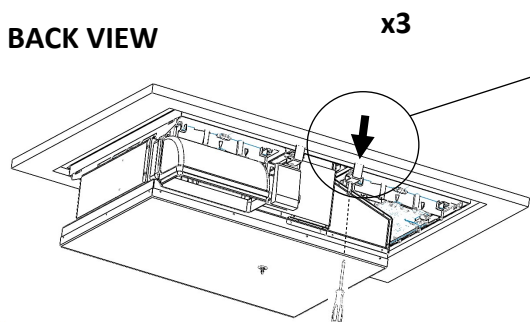
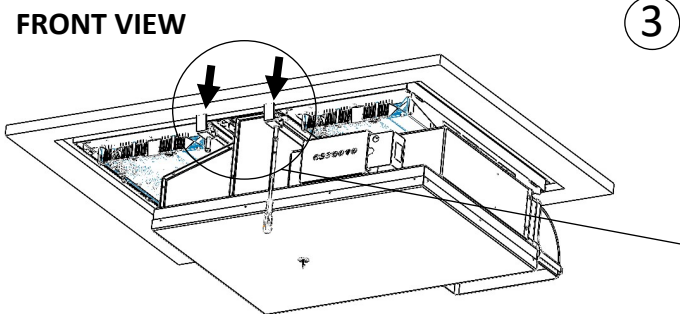
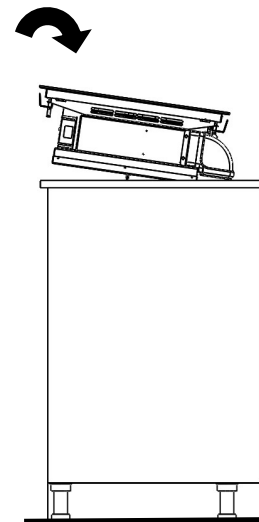
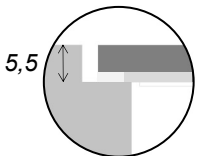
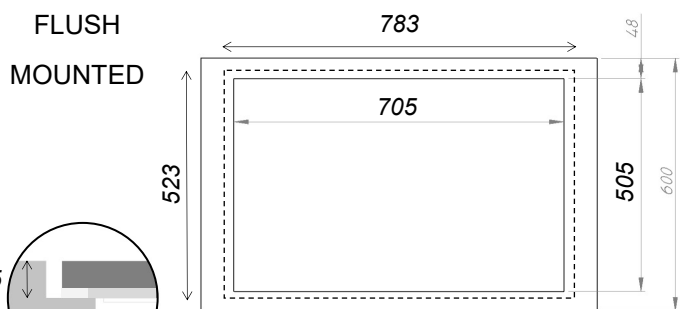
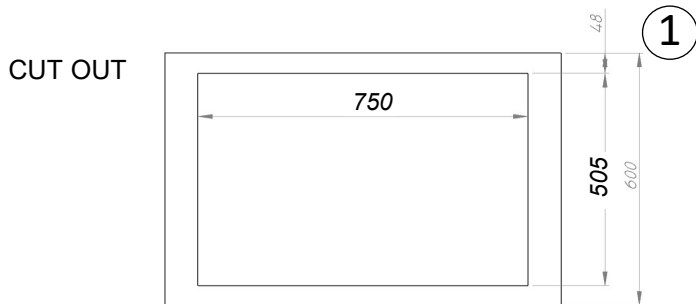
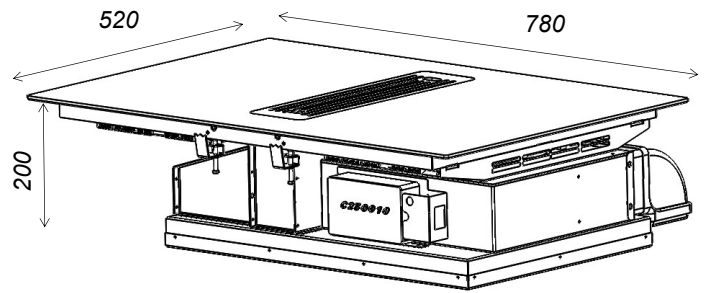

5

220V-240V (50hz/60hz) - 1F+N+T

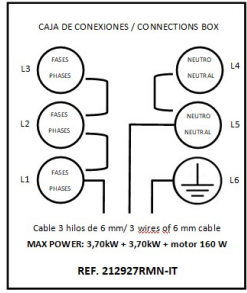
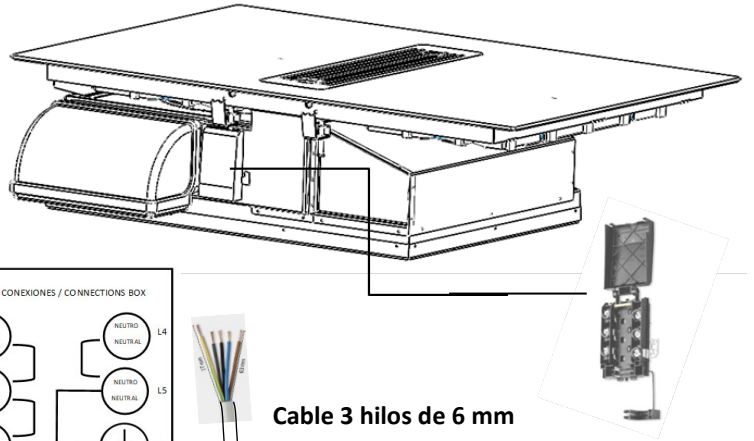
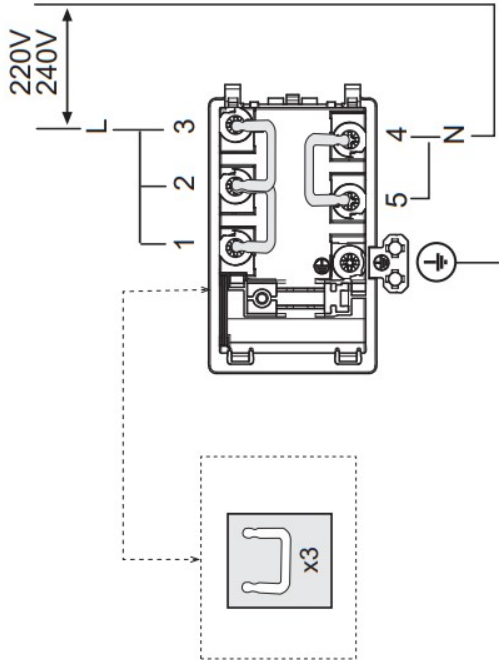

Cable 3 hilos de 6 mm
 3 wires of 6 mm cable

MAX POWER: 3,70kW + 3,70kW + motor 160 W

6

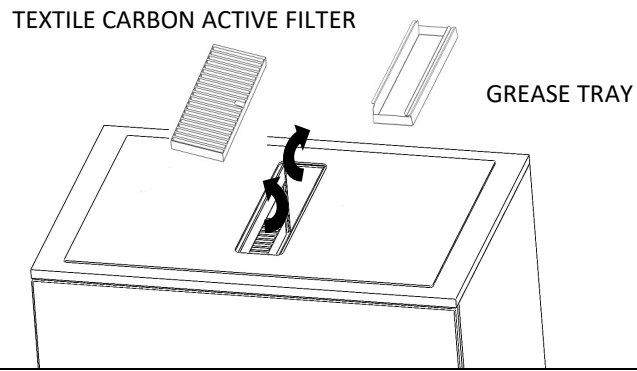
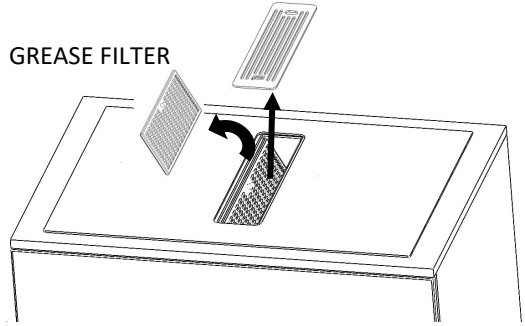

7

OPCIONAL

KIT INSTALACION ZÓCALO/ PLINTH KIT (90429)

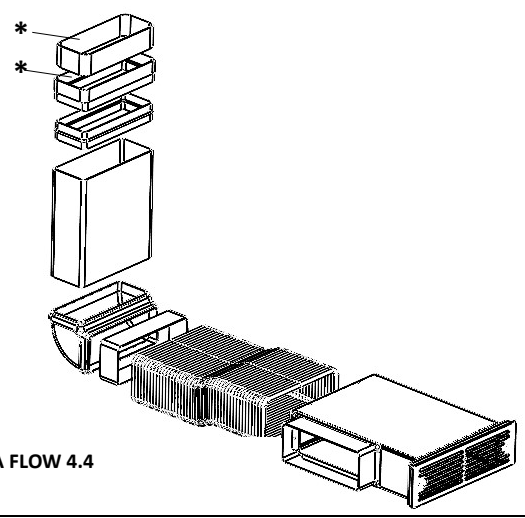

* SOLO PARA FLOW 4.4

8

